

| REV | DESCRIPTION | BY | CHK | DATE | ECN |
|-----|---------------------|-----|-----|---------|--------|
| A | ENGINEERING RELEASE | RAF | | 2-14-95 | MI3107 |

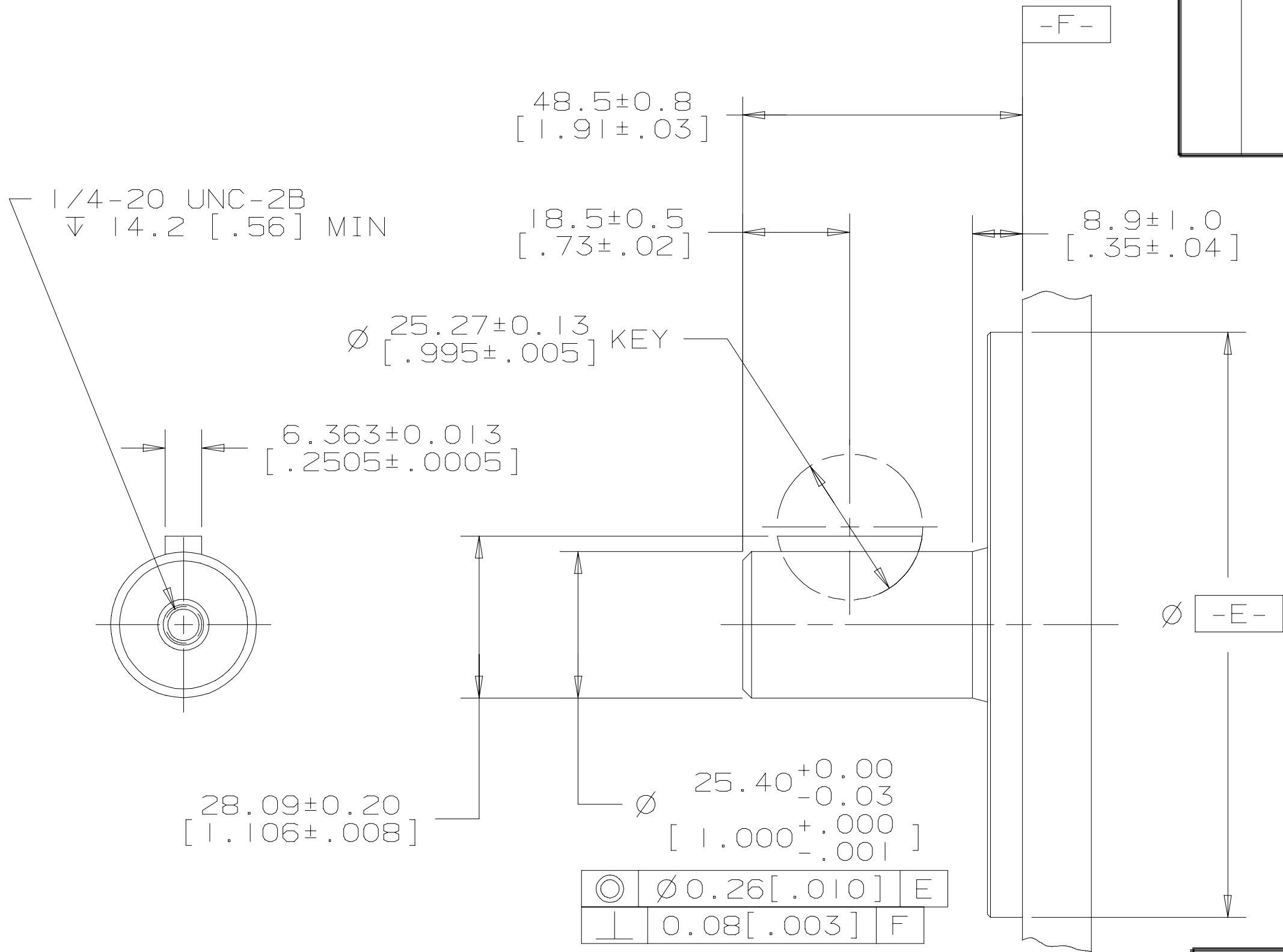

G M S

NOTE

1 OUTPUT SHAFT
 01 = Ø 25.4 [1.00] STRAIGHT WITH WOODRUFF
 KEY AND 1/4-20 THREADED HOLE

| | | |
|---|---|---|
| UNLESS OTHERWISE SPECIFIED ALL DIMENSIONS ARE IN INCHES <input type="checkbox"/> MILLIMETERS <input checked="" type="checkbox"/> TOLERANCES .X ± ---- .XX ± ---- .XXX ± ---- < ± ---- UNSPECIFIED RADII ARE ---- UNSPECIFIED DRAFT ANGLES ARE ---- DRAWING FORMAT CADD <input checked="" type="checkbox"/> MANUAL <input type="checkbox"/> | DRAWING BASED ON ANSI Y14.5M-1982 | |
| | THE REPRODUCTION, DISTRIBUTION, AND UTILIZATION OF THIS DOCUMENT, AS WELL AS THE COMMUNICATION OF ITS CONTENTS TO OTHERS WITHOUT EXPLICIT AUTHORIZATION IS PROHIBITED. OFFENDERS WILL BE HELD LIABLE FOR THE PAYMENT OF DAMAGES. ALL RIGHTS RESERVED IN THE EVENT OF THE GRANT OF A PATENT, UTILITY MODEL, OR DESIGN. (PER ISO 16016) | |
| DRAWN BY/DATE RAF 2-14-95 CHECKED BY/DATE ENGRG BY/DATE METALLURGY BY/DATE | MATERIAL/HEAT TREAT TITLE SHAFT INSTALLATION | |
| MICROINCHES <input type="checkbox"/> MICROMETERS <input type="checkbox"/> THIRD ANGLE PROJECTION <input checked="" type="checkbox"/> DO NOT SCALE | ARITHMETICAL AVERAGE <input checked="" type="checkbox"/> | NUMBER A-723-001 SCALE 1/1 SHEET 1 OF 1 |

