

THE REPRODUCTION, DISTRIBUTION AND UTILIZATION OF THIS DOCUMENT AS WELL AS THE COMMUNICATION OF ITS CONTENTS TO OTHERS WITHOUT EXPLICIT AUTHORIZATION IS PROHIBITED. OFFENDERS WILL BE HELD LIABLE FOR THE PAYMENT OF DAMAGES. ALL RIGHT RESERVED IN THE EVENT OF THE GRANT OF A PATENT, UTILITY MODEL OR DESIGN. (PER ISO 18018)

REVISIONS

REV	DESCRIPTION	DATE	APPROVED
F	REDRAWN - SUPERSEDES 1GA_FRA_SHEET 2 REV."E" FOR 1GABFRAB	11-27-95	EN-F16101 DP-24900

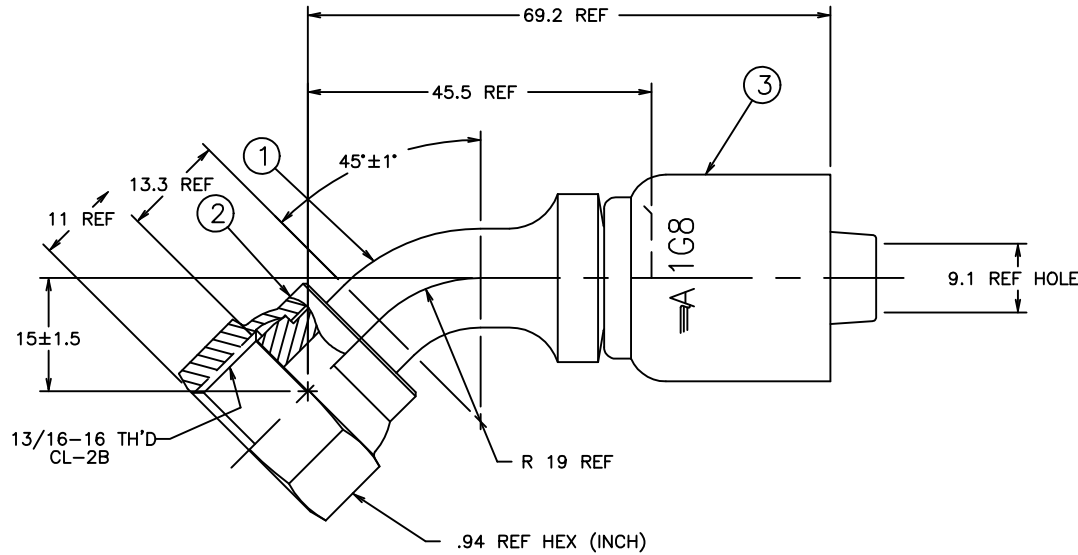

69.2	2.72
45.5	1.79
19	.75
15±1.5	.59±.06
13.3	.52
11	.43
9.1	.36
MM	INCH

CONVERSION

METRIC

2. ISABFRAB NIPPLE ASSEMBLY MAY BE SUBSTITUTED FOR ITEMS #1 & #2.
1. PROCESS AS FOLLOWS:
- BEND NIPPLE TO DIMENSIONS SHOWN.
 - ZINC PLATE PER ACES 2751.
 - CRIMP NUT PER ACES 2409P1.
 - ASSEMBLE SOCKET PER ACES 2813.

1GABFRAB	1F40022-0808AB	FC1473-08S	1G8		
AEROQUIP PART NUMBER	① NIPPLE	② NUT	③ SOCKET		
LIST OF MATERIALS					
ITEM NO.	MATERIAL	DRAWN M.MOLINA			
1	STEEL	CHECKED R.D.GARRETT			
2	STEEL	APPROVED R.D.GARRETT			
3	STEEL	RELEASE DATE 11-27-95			
		EN-F16101 DP-24900			
		THIRD ANGLE PROJECTION			
		SIZE C	DRAWING NUMBER 1GABFRAB	REV F	
		SCALE 2/1	DIST U	CAGE CODE 01276	SHEET NO

Danfoss FLUID CONVEYANCE DIVISION

DRAWING TITLE
FITTING ASSEMBLY
45°, ORS FEMALE SWIVEL, OTC