

REVISIONS			
REV	DESCRIPTION	DATE	APPROVED
H	REDRAWN & REDESIGNED - LAST REV "G" (WAS BRAZE DESIGN)	8-8-96	EN-F16596 DP-1141
J	1) FINISH WAS "ZINC PLATE PER ACES 2751"	2019-12-31 MBK	CO-0198171 A-2019/7548

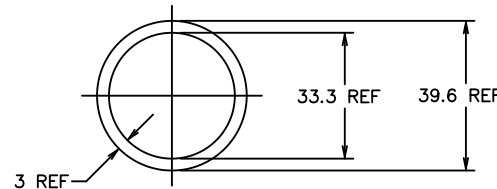
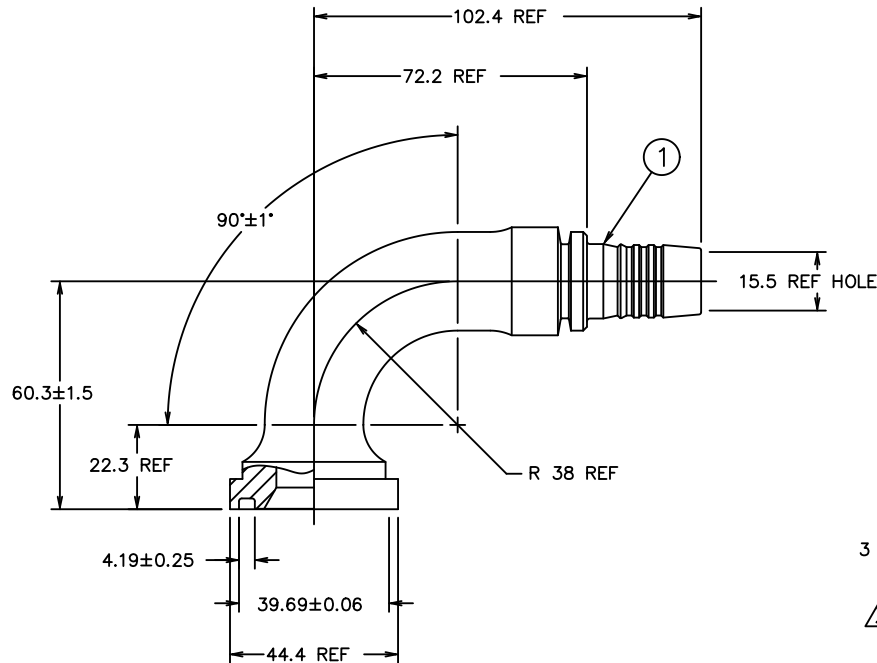

△ O'RING DETAIL

102.4	4.03
72.2	2.84
60.3±1.5	2.37±.06
44.4	1.75
39.69±0.06	1.5625±.0025
39.6	1.56
38	1.50
33.3	1.31
22.3	.88
15.5	.61
4.19±0.25	.165±.010
3	.12
MM	INCH

CONVERSION

METRIC

△ O'RING SHOWN FOR REFERENCE ONLY. SUPPLIED BUT NOT FURNISHED WITH ASSEMBLY.

- PROCESS AS FOLLOWS:
 - BEND NIPPLE TO DIMENSIONS SHOWN.
 - ZINC PLATE PER ES 2751D8 (1)

1S16FLB12	1F40041-1612AB				
PART NUMBER	(1) NIPPLE				
LIST OF MATERIALS					
ITEM NO.	MATERIAL	DRAWN J.L. HUFFMAN	FLUID CONVEYANCE DIVISION DRAWING TITLE NIPPLE ASSEMBLY 90° SPLIT FLANGE TYPE (CODE 61) 2781 HOSE		
1	STEEL	CHECKED R.D. GARRETT			
		APPROVED R.D. GARRETT			
		RELEASE DATE 8-9-96			
		EN-F16596	SIZE A2	DRAWING NUMBER 1S16FLB12	REV J
		DP-1141	SCALE 1/1	DIST R	CAGE CODE 01276
		THIRD ANGLE PROJECTION	SHEET 1		
<small>THE REPRODUCTION, DISTRIBUTION AND UTILIZATION OF THIS DOCUMENT AS WELL AS THE COMMUNICATION OF ITS CONTENTS TO OTHERS WITHOUT EXPLICIT AUTHORIZATION IS PROHIBITED. OFFENDERS WILL BE HELD LIABLE FOR THE PAYMENT OF DAMAGES. ALL RIGHT RESERVED IN THE EVENT OF THE GRANT OF A PATENT, UTILITY MODEL OR DESIGN. (PER ISO 16016)</small>					