

REVISIONS			
REV	DESCRIPTION	DATE	APPROVED
K	REDRAWN -- SUPERSEDES 1SA_FRB_SHEET 2 REV."J" FOR 1SA4FRB4 (1) WAS 8.2 REF	11-3-95	EN-F16053 DP-24900
L	1) FINISH WAS ZINC PLATE PER ACES 2751".	2020-06-26 ASB	CO-0205138

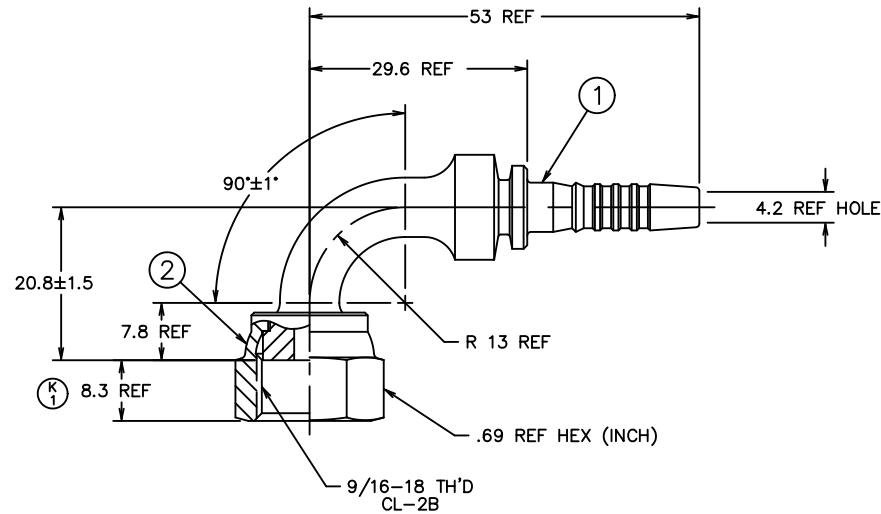

53	2.09
29.6	1.17
20.8±1.5	.82±.06
13	.51
8.3	.33
7.8	.31
4.2	.17
MM	INCH

CONVERSION

METRIC

1. PROCESS AS FOLLOWS:  
 (a) BEND NIPPLE TO DIMENSIONS SHOWN.  
 (b) ZINC PLATE PER ES 2751D8.  
 (c) CRIMP NUT PER ACES 2409P1.

1SA4FRB4	1F40023-0404AB	FC1473-04S			
AEROQUIP PART NUMBER	① NIPPLE	② NUT			
LIST OF MATERIALS					
ITEM NO.	MATERIAL	DRAWN R.D. GARRETT	FLUID CONVEYANCE DIVISION DRAWING TITLE <b>NIPPLE ASSEMBLY</b> 90°, ORS FEMALE SWIVEL, 2781 HOSE		
1	STEEL	CHECKED M. MOLINA			
2	STEEL	APPROVED R.D. GARRETT			
		RELEASE DATE 1995-11-07			
		EN-F16053	SIZE A3	DRAWING NUMBER 1SA4FRB4	REV L
		DP-24900	THIRD ANGLE PROJECTION	SCALE 2/1	DIST U
				CAGE CODE 01276	SHEET
<small>THE REPRODUCTION, DISTRIBUTION AND UTILIZATION OF THIS DOCUMENT AS WELL AS THE COMMUNICATION OF ITS CONTENTS TO OTHERS WITHOUT EXPLICIT AUTHORIZATION IS PROHIBITED. OFFENDERS WILL BE HELD LIABLE FOR THE PAYMENT OF DAMAGES. ALL RIGHT RESERVED IN THE EVENT OF THE GRANT OF A PATENT, UTILITY MODEL OR DESIGN. (PER ISO 18016)</small>					